

GRUA TORRE / TOWER CRANE

GRUE A TOUR / БАШЕННЫЙ КРАН /

KULE VİNG / رافعة برجية

J85



EN 14439
C25

UNE-EN-ISO 9001

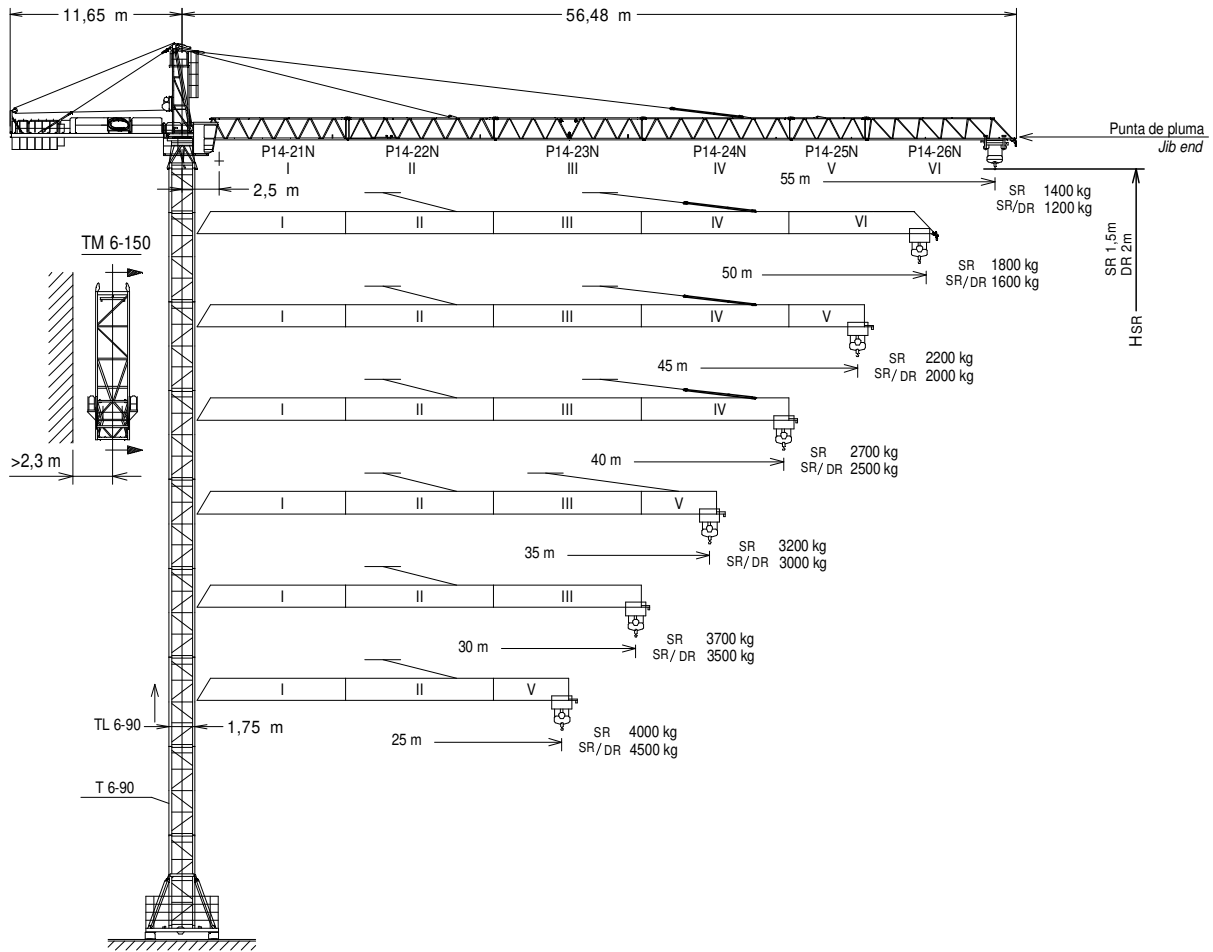

$H_{DR} = H_{SR-0,5}$

Altura máxima bajo gancho sin arriostrar (m).
Maximum height under hook without fastening (m).

Hauteur maximale sous crochet sans ancrage (m).

$H_{SR} =$ Максимальная высота под крюком без крепления (m).

Bağlantısız maksimum kanca altı yüksekliği (m).

أقصى ارتفاع تحت الخطاف بدون ربط

* Punta de pluma / Jib end / Pointe de flèche / Конец стрелы / Вом ісу / مقدمة الذراع

TM 6-150	161.35.700	BNI 45-100	145.20.500
T 3-90	133.32.000	BNI 6-150	161.20.000
TL 3-90	158.32.000	ABH 100	201.23.000
T 6-90	133.31.000	P14-21N	158.40.000
TL 6-90	158.31.000	P14-22N	158.41.000
T 6-150	161.31.000	P14-23N	158.42.000
T 6-150A	161.31.300	P14-24N	158.43.000
AN 90	133.21.000	P14-25N	158.44.000
AN 150	161.21.000	P14-26N	158.45.500
		Punta de pluma / Jib end*	158.46.000

(H) TRASLACIÓN / TRAVELLING /

TRASLATION / ПЕРЕМЕЩЕНИЕ / RAY YÜRÜYÜŞLÜ / متحركة

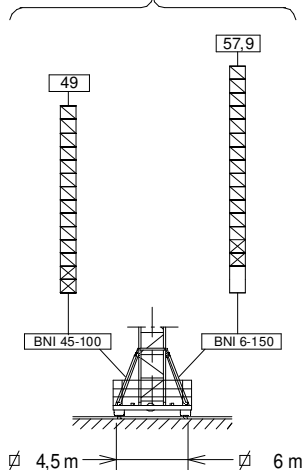

(H) ESTACIONARIA / STATIONARY /

STATIONAIRE / СТАЦИОНАРНОЕ СОСТОЯНИЕ / САБИТ / ثابتة

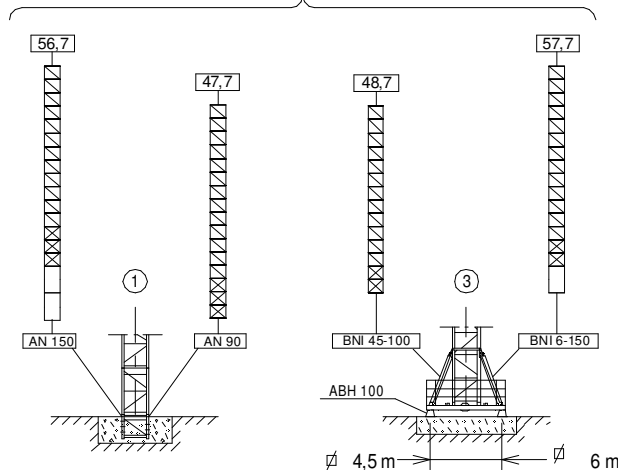

- T 3-90
- TL 3-90
- T 6-90
- TD 6-90
- TL 6-90
- T6-150A
- T6-150
- TD6-150

Fecha / Date: 20/01/2016



Reservado el derecho a modificaciones sin previo aviso. Declinamos toda responsabilidad derivada de la información proporcionada / Subject to modification, without previous warning. This information is supplied without liability / L'entreprise se réserve le droit de procéder à des modifications sans préavis. Nous déclinons toute responsabilité quant aux informations fournies / Мы оставляем за собой право на внесение изменений без предварительного уведомления. Мы снимаем с себя любую ответственность в отношении предоставленной информации / Önceden bildirilmeksizin değiştirilme hakkı saklıdır. Verilen bilgiler için hiçbir sorumluluk kabul etmemekteyiz / حقوق التغيير محفوظة دون إشعار مسبق. دون أدنى مسؤولية عن المعلومات المقدمة













FEM 1005 - C25

سرب / SR (kg)		Cargas máximas / Maximum loads / Charges maximales / Максимальные нагрузки / Maksimum yük / أقصى حمولة						
		SR1-3.000 kg SR2-4.000 kg						
[m]	3000-4000 kg @ ... (m)	Alcance del gancho [m] / Hook reach [m] / Portée du crochet (m) / Радиус действия крюка (m) / Kancanın yüksekliği (m) / مدى الخطاف						
		25	30	35	40	45	50	55
55 m	29,12-22,5	3000-3560	2900	2430	2075	1800	1580	1400
50 m	32,35-25,0	3000-4000	3000-3265	2745	2350	2045	1800	—
45 m	34,41-26,59	3000-4000	3000-3500	2945	2525	2200	—	—
40 m	36,47-28,18	3000-4000	3000-3735	3000-3145	2700	—	—	—
35 m	35,0-28,64	3000-4000	3000-3800	3000-3200	—	—	—	—
30 m	30,0-27,95	3000-4000	3000-3700	—	—	—	—	—
25 m	25,0	3000-4000	—	—	—	—	—	—

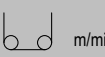
سرب / در / SR / DR (kg)		Cargas máximas / Maximum loads / Charges maximales / Максимальные нагрузки / Maksimum yük / أقصى حمولة								
		SR1 / DR1 - 3.000 / 6000 kg								
[m]	3000 / 6000 kg @ ... (m)	Alcance del gancho [m] / Hook reach [m] / Portée du crochet (m) / Радиус действия крюка (m) / Kancanın yüksekliği (m) / مدى الخطاف								
		15	20	25	30	35	40	45	50	55
55 m	27,5 / 15,0	3000 / 6000	3000 / 4350	3000 / 3360	2700	2230	1875	1600	1380	1200
50 m	30,56 / 16,67	3000 / 6000	3000 / 4900	3000 / 3800	3000 / 3065	2540	2150	1845	1600	—
45 m	32,5 / 17,75	3000 / 6000	3000 / 5250	3000 / 4080	3000 / 3300	2745	2325	2000	—	—
40 m	34,44 / 18,79	3000 / 6000	3000 / 5600	3000 / 4360	3000 / 3535	2945	2500	—	—	—
35 m	35,0 / 19,09	3000 / 6000	3000 / 5700	3000 / 4440	3000 / 3600	3000	—	—	—	—
30 m	30,0 / 18,64	3000 / 6000	3000 / 5550	3000 / 4320	3000 / 3500	—	—	—	—	—
25 m	25,0 / 19,32	3000 / 6000	3000 / 5775	3000 / 4500	—	—	—	—	—	—

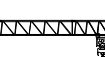
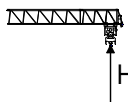
CARACTERISTICAS DE MECANISMOS / MECHANISMS FEATURES / CARACTÉRISTIQUES DES

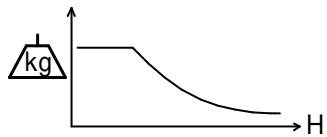
MÉCANISMES / ХАРАКТЕРИСТИКИ МЕХАНИЗМОВ / MEKANİZMALARIN ÖZELLİKLERİ / الخصائص الآلية

*opcional *optional *en option *опция *opsiyonel *اختياري														
	EC2556 SR1 18,4 kW		* EC3380VF SR1 24,2 kW		EC2544 SR2 18,4 kW			*EC3360VF SR2 24,2 kW		TG1125VF 2x4 kW	OG1108VF 2x4 kW	TC465VF 3 kW	TH1210 9,2 kW	
 m/min	1,5	3	3	1,5	3	2	4	4	2	4	0...25 m/min	0...0,8 r/min / sl/min	0...15 15...32 32...65 m/min	1 m/min
 m/min	56	28	7	0...80	0...40	44	22	5,5	0...60	0...30				
 m/min	3	6	6	3	6									
	28	14	4	0...40	0...20									
 H ≤ SR 240 m DR 120 m					SR 272m				 P _{TOTAL} (EC25XX + OG1108VF + TC465VF) = 29,4 kW P _{TOTAL} (*EC33XXVF + OG1108VF + TC465VF) = *35,2 kW					
									 480V 60Hz EC2556 EC2544 TH1210 kW +20% m/min +20%					

Fecha / Date: 20/01/2016

FEM 1005 - C25







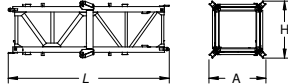
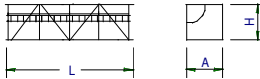
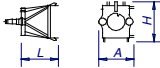
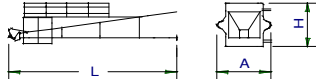
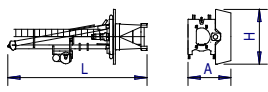
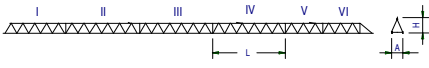

Reservado el derecho a modificaciones sin previo aviso. Declinamos toda responsabilidad derivada de la información proporcionada / Subject to modification, without previous warning. This information is supplied without liability / L'entreprise se réserve le droit de procéder à des modifications sans préavis. Nous déclinons toute responsabilité quant aux informations fournies / Мы оставляем за собой право на внесение изменений без предварительного уведомления. Мы снимаем с себя любую ответственность в отношении предоставленной информации / Onceden bildirimeksizin değiştirme hakkı saklıdır. Verilen bilgiler için hiçbir sorumluluk kabul etmemekteyiz / حقوق التغيير محفوظة دون إشعار مسبق. دون أدنى مسؤولية عن المعلومات المقدمة

LISTA DE EMBARQUE / PACKING LIST /

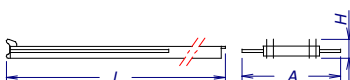
LISTE DE COLISAGE / СПИСОК ПОСТАВКИ / ÇEKİ LİSTESİ / قائمة التحميل

J85

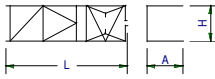
DENOMINACIÓN / DENOMINATION / DÉSIGNATION / НАЗВАНИЕ / AÇIKLAMA / اسم		L [m]	A [m]	H [m]	P / W [kg]	
Torre inferior / Lower tower / Tour inférieure Нижняя башня / Alt kule / البرج السفلي	T16-90 T16-150		6,146 6,175	2,085 2,190	2,085 2,190	2500 3535
Torre Tower Tour Башня Kule برج	T3-90 TL3-90 T6-90 TL6-90 T6-150 T6-150A		3,190 3,196 6,140 6,136 6,175 6,175	1,818 1,818 1,818 1,818 1,870 1,870	1,818 1,818 1,818 1,818 1,870 1,870	1200 960 2250 1785 2760 2760
Torre asiento pista + base punta de torre + orientación Slewing table + tower head base + slewing mechanism Tour pivot + base du porte-flèche + mécanisme d'orientation Сиденье площадки + основание верхней секции башни + поворотный механизм Göbek +kule kafa bölümü tabanı+mekanizma برج وحدة الدوارن + قاعدة رأس البرج + آلية الدوران			3,390	2,060	2,150	3400
Punta de torre / Tower head / Porte-flèche верхняя секция башни / kulenin kafa bölümü / رأس البرج			6,164	1,200	1,350	1210
Conjunto asiento pista, punta de torre, orientación y elevación Slewing table assembly, tower head, slewing and hoisting mechanism Groupe pivot + porte-flèche + mécanisme d'orientation + de levage Сиденье площадки + верхняя секция башни + поворотный механизм + подъемный механизм Göbek +kulenin kafa bölümü+mekanizma+vinç kulesi مجموعة وحدة الدوارن + رأس البرج + آلية الدوران + آلية الرفع			8,5	1,920	2,440	5660
Tramo de pluma Jib section Tronçon de flèche Секция стрелы Вот bölümü أجزاء الذراع	P14-21N (I) P14-22N (II) P14-23N (III) P14-24N (IV) P14-25N (V) P14-26N (VI)		10,150 10,160 10,160 10,160 5,267 10,156	1,366 1,226 1,226 1,226 1,226 1,226	1,665 1,646 1,547 1,547 1,665 1,737	965 945 785 655 345 530
Polipasto / Hook assembly / Palan / Полупаст / Kanca takımı / بكرة	SR DR		0,76 1	0,160 0,235	0,960 1,288	190 293
Carro / Trolley / Chariot / Грузовая тележка / Şaryo / عربة	SR DR		1,100 1,410	1,330 1,471	0,730 1,204	195 295
Contrapluma con plataformas / Counterjib with platforms Contre-flèche avec plateformes / Противовесная консоль с платформами / Platformlu kuşruk / المقابل مع المنصة / الذراع			10,70	1,410	0,430	1575
Plataforma y cabina / Platform and cabin / Plateforme et cabine Платформа и кабина / Platform ve kabin / منصة وكابينة			3,760	2,050	2,400	1280
Contrapeso / Counterweight / Contrepoids / Противовес / Denge ağırlığı / اوزان معاكسة / Grande / Big / Grand / Большой / Büyük / كبير Pequeño / Small / Petit / Малый / Küçük / صغير			1,08 1,08	0,50 0,50	2,02 1,30	2360 1500
Lastre / Ballast / Lest / Балласт / Alt ağırlık taşları / ثقل			3,800	0,580	1,500	6000
Estructura torre de montaje / Jacking cage structure / Structure de tour de montage / Структура монтажной башни / Kaldırma kafesi yapısı / هيكل برج التركيب	TM 6-150		10,320	2,420	2,410	3500

LASTRES INFERIORES / LOWER BALLASTS / LESTS INFÉRIEURS / НИЖНИЙ БАЛЛАСТ / ALT AĞIRLIK TAŞLARI / ثقل

J85

BNI 45-100	H (m)	19,4	31,2	37,3	43,1	49
	P (t)	36	48	60	72	84
BNI 6-150	H (m)	28	37	45,8	51,8	57,9
	P (t)	36	48	60	72	96

H: Altura bajo gancho / Height under hook / Hauteur maximale sous crochet / Высота под крюком / Kanca alti yüksekliği / الارتفاع أسفل الخطاف /
 Para alturas intermedias tomar el lastre correspondiente a la altura superior / For intermediate heights take the ballast corresponding to the higher height / Pour les hauteurs intermédiaires, opter pour le lastre correspondant à la hauteur immédiatement supérieure / Для промежуточных высот возьмите балласт, соответствующий большей высоте / Orta yükseklikler için daha üst bir yüksekliği kaşılık gelen ağırlığı alınız. / لارتفاعات البينية يرجى استخدام الثقل العائد للارتفاع الأعلى /



Fecha / Date: 20/01/2016



FEM 1005 - C25

Reservado el derecho a modificaciones sin previo aviso. Declinamos toda responsabilidad derivada de la información proporcionada / Subject to modification, without previous warning. This information is supplied without liability / L'entreprise se réserve le droit de procéder à des modifications sans préavis. Nous déclinons toute responsabilité quant aux informations fournies / Мы оставляем за собой право на внесение изменений без предварительного уведомления. Мы снимаем с себя любую ответственность в отношении предоставленной информации / Önceden bildirilmesizin değiştirilme hakkı saklıdır. Verilen bilgiler için hiçbir sorumluluk kabul etmemekteyiz / حقوق التغيير محفوظة دون إشعار مسبق. دون أدنى مسؤولية عن المعلومات المقدمة

T	H					T	H	
1	3,6	TL 3-90	TL 3-90	TL 3-90	2,95	1	3,6	
2	6,5					2	6,5	
3	9,5					3	9,5	
4	12,4					4	12,4	
5	15,4					5	15,4	
6	18,3					6	18,3	
7	21,3					7	21,3	
8	24,2					8	24,2	
9	27,2					9	27,2	
10	30,1					10	30,1	
11	33,1					11	33,1	
12	36					12	36	
13	39	T 3-90	T 3-90	T 3-90	2,95	13	39	
14	41,9					14	41,9	
15	44,8		T6-150A	T6-150A	5,82	14	44,8	
16	47,7					15	50,6	
		16	50,8	T6-150	5,82	15	50,6	
		17	56,7	T6-150		16	54,6	
						17	60,2	
		18	60,3	TL20 / TX 150	3,93	16	54,6	
		19	64,2	TL20-5,6	204.31.400	5,6	17	60,2
						18	65,8	
						19	71,4	
						20	74,2	
						21	79,8	
						22	85,4	

AN 90 133.21.000
 AND 90 133.21.800
 AN 150 161.21.000
 AND 150 161.21.050
 AL 20 153.21.800
 ALD 20 160.21.250
 AS 20 160.21.010
 ASD 20/24 160.21.080
 ASR 20 160.21.200
 ASRD 20/24 156.21.000

T: Torre / Tower / Tour / Башни / Kuleler / أبراج
 H: Altura / Height / Hauteur / Высота / Yükseklik / ارتفاع

Otras configuraciones de torre / Other tower configuration / Autres configurations / Прочие конфигурации / Diğer konfigürasyonlar / مكونات أخرى

Transporte
 Transport / Transport /
 Транспортировка / Taşıma / نقل

H=49 + + BNI 45 100

6x

7x HIGH CUBE 40'

h_{max}: T6-90T + 13xTL3-90

h (m)	44,9
D (m)	10 - 20
P (KN)	579 519
Rmax (KN)	123 242

T6-90T = 139.32.700

Trepado interno / Internal climbing. / Téléscopage intérieur / Внутренняя лестница / Bina içi tirmanma / التسلق الداخلي

- ⚠ Viento fuera de servicio / Out of service wind / Vitesse du vent hors service / Ветровая нагрузка в покое / Rüzgar devre dışı / الرياح خارج الخدمة
- 📄 Consultar / Consult / Nous consulter / Консультируйтесь / Danışınız / الرجوع إلى
- ▶ En servicio / In service / En service / В работе / Devrede / في الخدمة
- Fuera de servicio / Out of service / Hors service / В покое / Devre dışı / خارج الخدمة



Ctra./Rd. Madrid - Irún Km. 415 - 20.213 IDIAZABAL [Gipuzkoa] ESPAÑA / SPAIN
 P.O. Box, 23 - 20.200 BEASAIN - E-mail: jaso@jaso.com
 Tel. +34 943 - 18 70 00 • Fax. +34 943 - 18 70 20
www.jaso.com

Fecha / Date: 20/01/2016

FEM 1005 - C25

DELEGACION / DEALER



Neutronweg 4, 1627 LG Hoorn
 The Netherlands
 +31 (0) 229 21 2642
 info@tekekranen.nl

Reservado el derecho a modificaciones sin previo aviso. Declinamos toda responsabilidad derivada de la información proporcionada / Subject to modification, without previous warning. This information is supplied without liability / L'entreprise se réserve le droit de procéder à des modifications sans préavis. Nous déclinons toute responsabilité quant aux informations fournies / Мы оставляем за собой право на внесение изменений без предварительного уведомления. Мы снимаем с себя любую ответственность в отношении предоставленной информации / Onceden bildirilmeksizin değiştirilme hakkı saklıdır. Verilen bilgiler için hiçbir sorumluluk kabul etmemekteyiz /

حقوق التغيير محفوظة دون إشعار مسبق. دون أدنى مسؤولية عن المعلومات المقدمة