

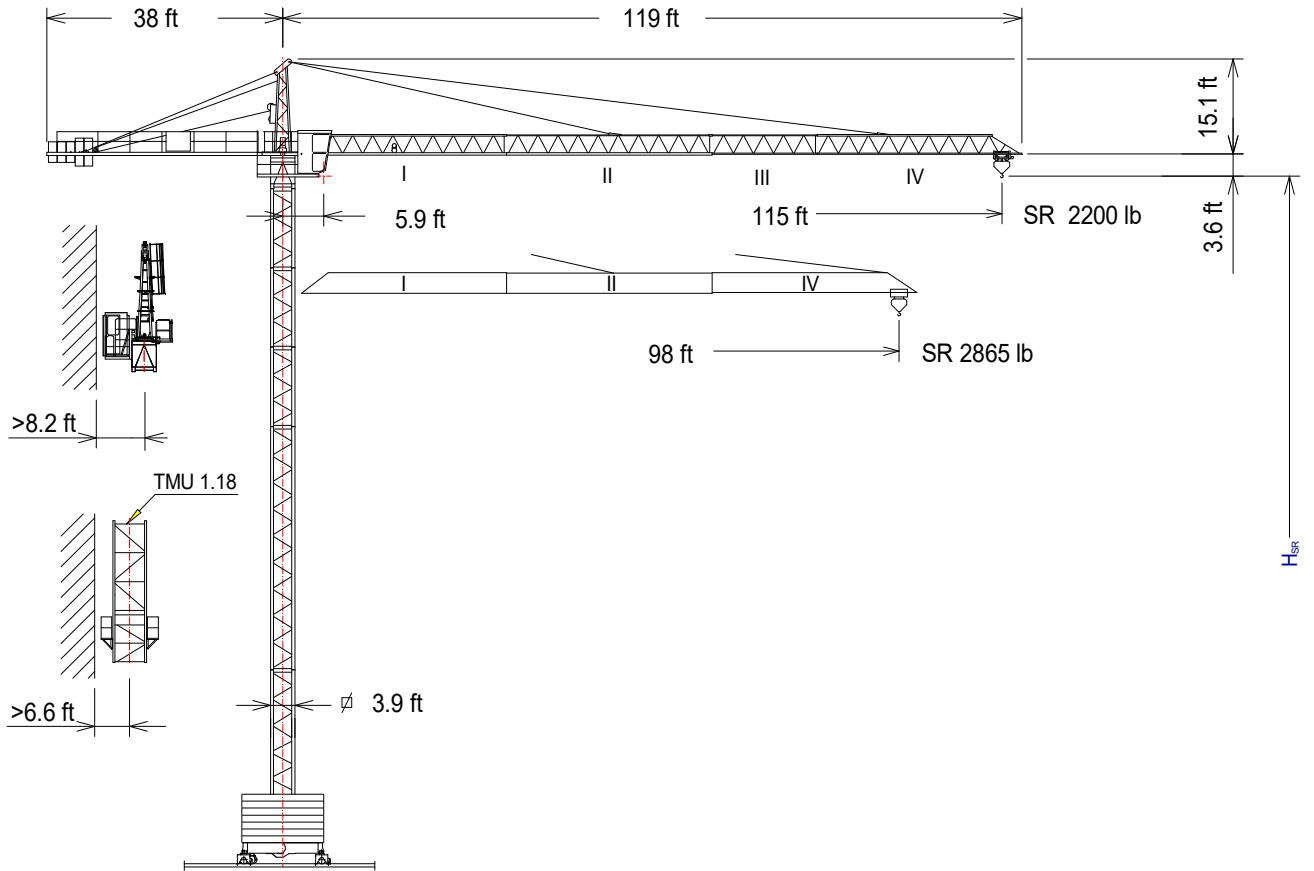

EN 14439
C25

UNE-EN-ISO 9001



H_{SR} = Altura máxima bajo gancho sin arriostrar (m).
Maximum height under hook without fastening (m).



$H_{SR} - 6.6$ ft.

* Pluma / Jib

Pluma / Jib (I) *	134.40.700	TN 2	146.32.500
Pluma / Jib (II)	134.41.000	AR 12	137.21.000
Pluma / Jib (III)	124.42.000	AN 12	146.21.000
Pluma / Jib (IV)	134.43.000	BTX 45/BEX 45	137.20.500
TMU 1.18	202.35.500	BTX 38R/BEX 38R	137.20.000
TR 12	146.30.000	BTX 38/BEX 38	149.20.000
T 12	126.31.500	BTX 28/BEX 28	149.20.500
TR 8RM	202.30.000	BE 442	146.24.850
TR 8M	146.30.800	BE 434	146.24.950
TR 4	800.32.300	ABH 75	152.23.000
T 4	126.32.000	ABH 90	146.23.000

(H) TRASLACIÓN / TRAVELLING

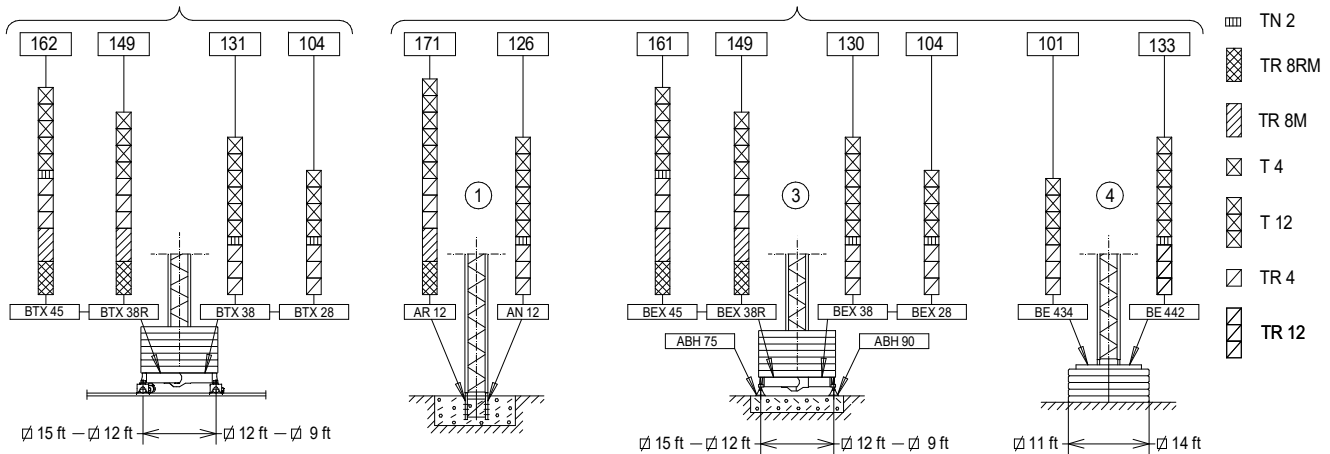

(H) ESTACIONARIA / STATIONARY













Fecha / Date: 04/06/2020

FEM 1005 - C25

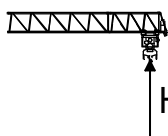
Reservado el derecho a modificaciones sin previo aviso. Declinamos toda responsabilidad derivada de la información proporcionada / Subject to modification, without previous warning. This information is supplied without liability

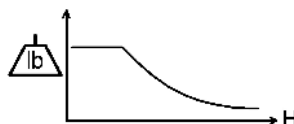
CARGAS / LOADS		Cargas máximas / Maximum loads							J36MAC
	SR (lb)	SR - 4400 lb							
	4400 lb @...[ft]	Alcance del gancho [ft] / Hook reach [ft]							
		66	72	82	89	98	105	115	
115	62	4175	3745	3250	2975	2645	2370	2200	
98	67	4400	4050	3525	3230	2865	—	—	

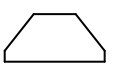
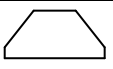
CARACTERISTICAS DE MECANISMOS / MECHANISMS FEATURES		J36MAC					
*opcional *optional							
	EC1540 11 kW	* EC1856 13,2 kW	9 / 12 / 15 ft TG825VF 2x3 kW	OG308 / *OG408VF 2,2 kW / *3 kW	TC240 1,5 kW	TH1010 9,2 kW	
	lb 2755 4400 4400 ft/min 131 66 16	lb 2425 4400 4400 ft/min 184 92 20	0...82 ft/min	0...0,8 r/min sl/min	131 ft/min	3.3 ft/min	
	H ≤ SR 633 ft			EC1540	AMPERAGE = 30 A		
			480V 60Hz	EC1856	AMPERAGE = 34 A		

LASTRES INFERIORES / LOWER BALLASTS		J36MAC					
	H (m)	51	91	104	131	149	162
BEX 45 / BTX 45		4	6	8	10	14	16
BEX 38R / BTX 38R		4	6	8	12	16	----
BEX 38 / BTX 38		4	6	8	12	----	
BEX 28 / BTX 28	 3700 kg	8	10	12	----		
	H (m)	66			101		
BE 434	 4300 kg	8			10		
	H (m)	91		105		133	
BE 442	 3450 kg	12		16		20	

H: Altura bajo gancho / Height under hook

Para alturas intermedias tomar el lastre correspondiente a la altura superior / For intermediate heights take the ballast corresponding to the higher height



Fecha / Date: 04/06/2020

 FEM 1005 – C25

Reservado el derecho a modificaciones sin previo aviso. Declinamos toda responsabilidad derivada de la información proporcionada / Subject to modification, without previous warning. This information is supplied without liability

DENOMINACIÓN / DENOMINATION		L [ft]	A [ft]	H [ft]	P / W [lb]		
Torre Tower	TR 8RM	26.5	3.9	3.9	5680		
	TR 8M	26.5	3.9	3.9	5545		
	TR 12	39.4	3.9	3.9	6260		
	T 12	39.4	3.8	3.8	4460		
	TR 4	13.0	3.8	3.8	2360		
	T 4	13.4	3.8	3.8	1750		
	TN 2	7.5	3.9	3.9	1730		
Conjunto asiento pista, punta de torre y orientación <i>Slewing table assembly, tower head and slewing mechanism</i>			20.4	4.3	6.8	5220	
Tramo de pluma <i>Jib section</i>	I	32.8	2.8	3.2	1420		
	II	32.8	2.8	3.2	960		
	III	16.8	2.8	3.2	450		
	IV	32.4	2.8	3.2	830		
Polipasto / Hook assembly		SR		2.5	0,5	3.2	220
Carro / Trolley		SR		3.2	3.3	1.55	190
Contrapluma con plataformas <i>Counterjib with platforms</i>			34.6	3.0	0,78	1980	
Torre de montaje / <i>Jacking cage</i>			23.4	5.8	5.6	7050	
Torre de montaje sin puerta, carro, plataforma carro y viga de apoyo <i>Jacking cage without door, trolley, trolley platform and beam assembly</i>		TMU 1.18 	23.4	5.8	5.6	5400	
Plataforma y cabina <i>Platform and cabin</i>			12.1	5.3	7.4	1800	
Base grúa Testero largo <i>Crane base Long carriage</i>	BTX 28		15.4	2.1	5.0	1346	
	BTX 38		20.0	2.1	5.0	1576	
	BTX 38R		20.0	2.1	5.1	1792	
	BTX 45		22.9	2.1	5.1	2065	
Base grúa Testero corto <i>Crane base Short carriage</i>	BEX 28		13.6	0,9	4.2	2970	
	BEX 38		18.2	0,9	4.2	3060	
	BEX 38R		18.2	0,9	4.6	3500	
	BEX 45		21.5	0,9	4.6	4110	
Mecanismo traslación grúa <i>Crane travelling mechanism</i>			3.1	1.8	2.2	645	
Lastre / <i>Ballast</i>	□ 9 ft		9.8	1.4	4.3	8160	
	□ 12 ft - □ 15 ft		13.1	1.1	4.3	9040	
	BE 442		6.8	1.1	6.9	3605	
	BE 434		11.2	1.1	5.5	9480	

T	H (ft)									H	T		
1	15	T 4 126.32.000	T 4	15	1	1	15	T 4	↓	T 4	↓	15	1
2	28			28	2	2	28		13		13	28	2
3	67	T 12 126.31.500	T 12	67	3	3	67	T 12	↑	T 12	↑	67	3
4	74	TN 2 146.32.500	TN 2	74	4	4	74	TN 2	↑ 7	TN 2	↑ 2,16	74	4
5	113	TR 12 146.30.000	TR 12	113	5	5	113		39	TR 12	↑	39	5
6	139	TR 8M 146.30.800 TX-90/TXXR	TR 8M	139	6	6	139	TR 8M	↑ 26	TR 8M	↑ 26	139	6
7	151	T 3-90	T 3-90	151	7	7	151	T3-90	10	T 3-90	10	151	7
8	161			161	8	8	170	T6-150A	↑ 19			161	8
9	170			180	9	9	183	TL20 / Tx 150	↑ 13	T6-150A	↑ 19	180	9
10	181			193	10	10	201	TL20-5,6	↑ 18	TL20 / Tx 150	↑ 13	193	10
				211	11	11	220	TS20-5,6A	↑ 18	TL20-5,6	↑ 18	211	11
				229	12	12	238	TSR20-5,6A	↑ 18	TS20-5,6	↑ 18	229	12
							257	ASR 20	18	TSR20-5,6	↑ 18	248	13
										ASR 20	18	266	14
												284	15

AN 90	133.21.000	ALD 20	160.21.250
AND 90	133.21.800	AS 20	160.21.010
AN 150	161.21.000	ASD 20/24	160.21.080
AND 150	161.21.050	ASR 20	160.21.200
AL 20	153.21.800	ASRD 20/24	156.21.000

T: Torre / Tower
H: Altura / Height

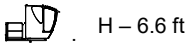

H - 6.6 ft

Transporte / Transport

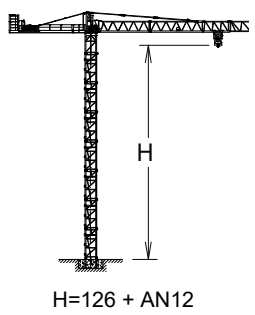

H=126 + AN12

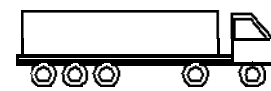
2x 

3x **HIGH CUBE 40'**

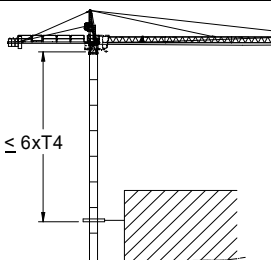

≤ 6xT4

TREPADO / CLIMBING

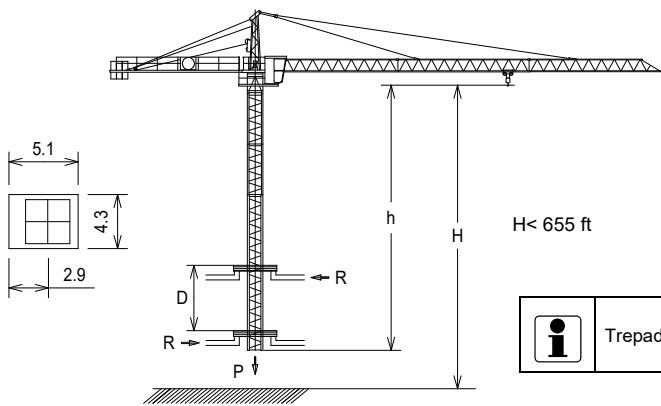





$h_{max} = 3xTR4 + T12 + 3xT4$

	▶	■
h (ft)	118	
D (ft)	21.6 - 32.8	
P (lbf)	61600	57100
Rmax (lbf)	20000	56400

TR4: 800.32.300

H < 655 ft

Trepado interno / Internal climbing

-  Viento fuera de servicio / Out of service wind
-  Consultar / Consult
-  En servicio / In service
-  Fuera de servicio / Out of service



Ctra./Rd. Madrid - Irún Km. 415 - 20.213 IDIAZABAL [Gipuzkoa] ESPAÑA / SPAIN
 P.O. Box, 23 - 20.200 BEASAIN - E-mail: jaso@jaso.com
 Tel. +34 943 - 18 70 00 • Fax. +34 943 - 18 70 20
www.jaso.com

Fecha / Date: 04/06/2020

 FEM 1005 - C25

DELEGACION / DEALER